



30303 Aurora Road  
Solon, Ohio, 44139-2794  
440-248-1200 - [www.bird-technologies.com](http://www.bird-technologies.com)

## INSTRUCTION SHEET

FOR

MODEL 72-2

COAXWITCH®

RF COAXIAL SELECTOR SWITCH

### GENERAL

The Bird Electronic Corporation Model 72-2 COAXWITCH® RF Coaxial Selector Switch is a two position, double-pole, double-throw manually operated switch for use in 50/51.5 ohm coaxial circuits. It is designed for applications which require frequent switching of coaxial circuits between antennas, transmitters, receivers, or other gear using 50 ohm coaxial impedances.

This switch is very rugged in construction and will meet most military specifications. The unit is housed in a black anodized aluminum casting, with nickel plated brass Female N connectors and connector plate. A selectively hardened cadmium plated ground steel shaft is used for the switching operation. The connectors and shaft have neoprene seals, making the entire switch installation splash proof.

### CHARACTERISTICS

Connectors.....	6 each Female N type
Useful Frequency Range.....	DC to 10 GHz
Maximum RF Voltage.....	500 Volts RMS
Attenuation to Unused Channel.....	75 dB (cross talk)
Ambient Operating Temperature.....	-60°C to +65°C (-76F to 149F)
Weight.....	2.5 lb (1.13 kg)

## ELECTRICAL PERFORMANCE DATA

<u>Frequency</u>	<u>VSWR</u>	<u>Insertion Loss</u>	<u>Max. RF Power Rating</u>
100 MHz		.02 dB	850 W
1 GHz	1.06:1 max.	.09 dB	200 W
4 GHz	1.30:1 max.	.22 dB	75 W

### INSTALLATION

Figure 1 illustrates the outline and mounting dimensions. Panel mounting is accomplished by means of three 10-32 x 3/8 inch Truss head machine screws through the dial plate and panel. Drill the mounting panel according to the face layout of the switch. Brackets are recommended for wall or table mounting. When installing the switch, take advantage of the manner in which the Female connectors are positioned, parallel to the axis of the switch. This eliminates the need for right-angle connectors, which results in a saving of space.

In order to realize the full possibilities of the COAXWITCH® RF selector switch, as a low VSWR device, it must be used with nominal 50 ohm cables such as RG-8A/U, RG-9B/U (213 or 214) or RG-87A/U and Male N type plugs. Other cables may be used, but with possible sacrifice of VSWR in some cases. Power handling capacity of switch is limited only by the capabilities of the internal RG-87/U cable and the N type connectors.

### OPERATION

To select the position desired, pull knob out, rotate, and push it in to make contact. The shaft push-pull motion is just over one-half inch. A ball and spring detent retains the rotor at the selected position. There is a 30° rotation between detents. A garter spring and ball mechanism assists in closing of the contacts, and will maintain firm contact even under shock and vibration.

### MAINTENANCE - LUBRICATION

The COAXWITCH® RF Selector Switch is rugged and simple. It requires only nominal routine care. Periodic cleaning of the RF connectors is recommended. Be sure to clean the insulator surfaces as well as the metal contacts. A little dry solvent such as alcohol or freon on a cotton swab stick should be used for cleaning. Avoid breathing the fumes when using solvents. Use only in a well ventilated area.

The switch may be opened for inspection by removing the screws on the connector end. If flexibility of the cables permits, they need not be disconnected to remove the entire cable connector plate. The rotor assembly may be lifted out if the knob has been removed.

Before lubricating the unit, clean the shaft and mating bearing shaft hole. Use light machine oil, a drop or two, on the center shaft. Do not allow oil to get into contacts. Use ball bearing grease, low temperature types, Andoc, etc., on the rotary detent ball, work into hole behind ball and on the three push-in balls on the inside of the housing at the bottom. A drop of oil on the shaft close to the dial plate, with the switch disengaged, will relieve drag at the neoprene shaft seal.

For access to the push-in balls and associated garter spring after the connector assembly and shaft have been removed, use a flat blade as a screw driver and unscrew the shaft bushing. Screw the bushing in tight when reassembling. The detent ball and the spring may be removed by pushing or driving with a small pin or drill into the side hole behind the ball.

FIGURE 1. MODEL 72-2 OUTLINE DRAWING

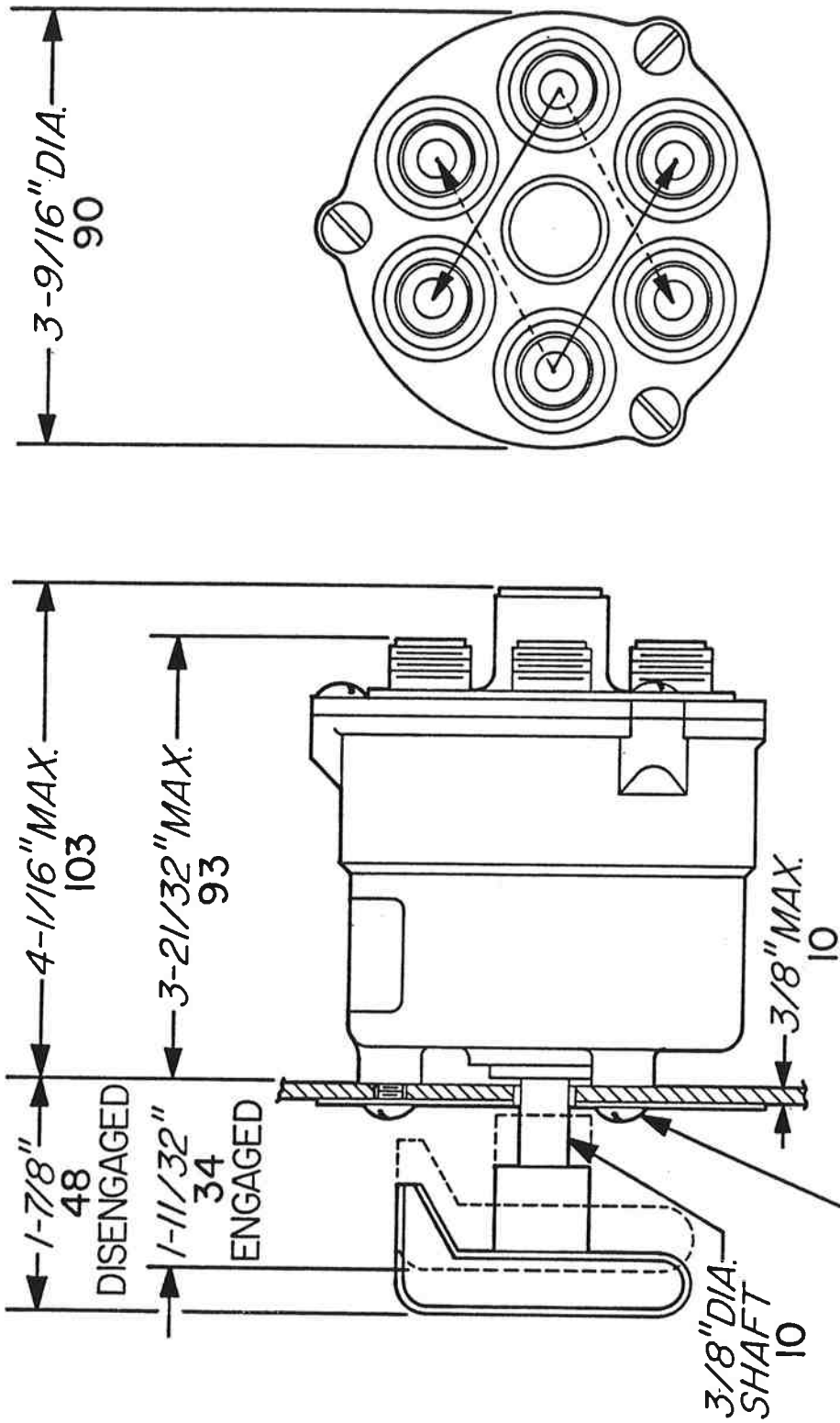

MOUNTING DIMENSIONS:  $7/32$ " (6mm) MTG. HOLES FOR THREE 10-32 SCREWS SPACED AT  $120^\circ$  ON  $1 - 1/4$ " (32mm) RADIUS